

*Liquids to Value*



## Order Code for **VESTA**<sup>®</sup> Sampling Valves

Type H\_AI 2/2 Way Seat Valve

Made by GEA Tuchenhagen

# Register



# VESTA® Sampling Valve, Type H\_A/I 2/2 Way Seat Valve

The VESTA® sampling valve is used for aseptic product sampling from pipes or tanks. The VESTA® sampling valve prevents product contamination, thus keeping the process system free from germs.



## Design features

- Aseptic bellows sealing system
- Pressure and vacuum resistant
- One-piece PTFE bellows for universal applications
- Defined pretension of the seal
- Self-locking groove nut connection
- Pocket-free design

## Benefits

- Valve body drains completely in straight pipes
- Reliable CIP/SIP cleaning thanks to optimised flow characteristics
- Long service life for the PTFE bellows
- Height of the valve body corresponds to that of the connecting piping
- Minimum space requirement, low process volume
- Easy and safe maintenance
- Wide range of body variants
- Sizes up to DN 65 available, larger sizes on request

## VESTA® and VARIVENT® - a strong team

In combination with our VARIVENT® and VARINLINE® series the requirement of full CIP/SIP compatibility is easily met.

As installation fitting for the VESTA® sampling valve the VARIVENT® and VARINLINE® access units are available with all their benefits:

- Pocket-free design, without domes and sumps
- Valve body drains completely, even in straight pipes
- Hermetic sealing of the valve interior against the external atmosphere using a patented bellows sealing system
- Reliable CIP/SIP cleaning thanks to optimised flow characteristics
- VARIVENT® / VARINLINE® interface

## Operating media

- Operating temperature -10 °C to max. 135 °C
- Sterilisation temperature max. 150 °C for 1h
- Operating pressure 0 to 6 bar

## Control air

- Control air temperature min. 0 °C, max. 70 °C  
- NO function
- Control air pressure min. 5 bar, max. 6 bar  
- NC function
- Control air pressure min. 5 bar, max. 8 bar
- Valve port cross-section 100 %

## Materials, product contact parts

- Housing 1.4435 (AISI 316L)
- Housing socket 1.4435 (AISI 316L)
- Delta ferrite content optional
- Bellows material TFM1705 (PTFE), FDA-conformity

## Materials, non-product contact parts

- Stainless steel actuator 1.4301 (AISI 304)
- Synthetic actuator polyphenylene sulphide (PPS)

# VESTA® Sampling Valve, Type H\_A/I 2/2 Way Seat Valve

Example for an order code

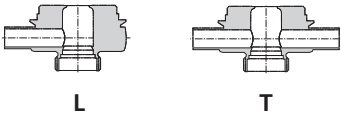
Code	Code	H	L	A	I/N	P	NW	NW	M	Z	000	0	0	-	0	2	52	K	-																																																				
Code	Item	1	2	3	4	5	6	7	8	9	10	11	12	13	14	15	16	17	18																																																				
<b>H</b>	<b>1. Valve type VESTA® Sampling Valve</b>																																																																						
	<b>2. Valve body combination</b>																																																																						
																																																																							
<b>A</b>	<b>3. Aseptic bellows seal</b>																																																																						
	<b>4. Housing specification</b>																																																																						
		<p>I/F = DN 25/32, ISO 33.7                      I/N = DN 40/50, ISO 42.4/48.3/60.3, OD 1.5"/2"                      I/S = DN 65/80, OD 2.5"/3"</p>																																																																					
<b>P</b>	<b>5. PTFE bellows seal</b>																																																																						
		<p>Bellows material TFM1705 (PTFE), conforms to: FDA, 21CFR 177.150, USP class VI                      For documentation see Item 16</p>																																																																					
	<b>6. Nominal width, process connection VESTA®</b>																																																																						
		<table border="1"> <thead> <tr> <th>DIN</th> <th colspan="12">Outside diameter acc. to DIN 11850, series II, DIN 11866, series A</th> </tr> <tr> <th></th> <th>Ø</th> <th>C</th> <th>D</th> <th>D1</th> <th>E</th> <th>H1</th> <th>H2</th> <th>H3</th> <th>H4</th> <th>H5</th> <th>X1</th> <th>X</th> </tr> </thead> <tbody> <tr> <td>DN 10</td> <td>13x1.5</td> <td>60</td> <td>50</td> <td>59</td> <td>40</td> <td>130</td> <td>163</td> <td>29.5</td> <td>113</td> <td>146</td> <td>187</td> <td>198</td> </tr> <tr> <td>DN 15</td> <td>19x1.5</td> <td>60</td> <td>50</td> <td>59</td> <td>40</td> <td>133</td> <td>163</td> <td>32.5</td> <td>116</td> <td>146</td> <td>197</td> <td>208</td> </tr> </tbody> </table>																		DIN	Outside diameter acc. to DIN 11850, series II, DIN 11866, series A													Ø	C	D	D1	E	H1	H2	H3	H4	H5	X1	X	DN 10	13x1.5	60	50	59	40	130	163	29.5	113	146	187	198	DN 15	19x1.5	60	50	59	40	133	163	32.5	116	146	197	208
DIN	Outside diameter acc. to DIN 11850, series II, DIN 11866, series A																																																																						
	Ø	C	D	D1	E	H1	H2	H3	H4	H5	X1	X																																																											
DN 10	13x1.5	60	50	59	40	130	163	29.5	113	146	187	198																																																											
DN 15	19x1.5	60	50	59	40	133	163	32.5	116	146	197	208																																																											
		<table border="1"> <thead> <tr> <th>ISO</th> <th colspan="12">Outside diameter acc. to DIN EN ISO 1127, series II, DIN 11866, series B</th> </tr> <tr> <th></th> <th>Ø</th> <th>C</th> <th>D</th> <th>D1</th> <th>E</th> <th>H1</th> <th>H2</th> <th>H3</th> <th>H4</th> <th>H5</th> <th>X1</th> <th>X</th> </tr> </thead> <tbody> <tr> <td>ISO 13.5</td> <td>13.5x1.6</td> <td>60</td> <td>50</td> <td>59</td> <td>40</td> <td>130</td> <td>163</td> <td>29.5</td> <td>113</td> <td>146</td> <td>187</td> <td>198</td> </tr> <tr> <td>ISO 17.2</td> <td>17.2x1.6</td> <td>60</td> <td>50</td> <td>59</td> <td>40</td> <td>133</td> <td>163</td> <td>32.5</td> <td>116</td> <td>146</td> <td>197</td> <td>208</td> </tr> </tbody> </table>																		ISO	Outside diameter acc. to DIN EN ISO 1127, series II, DIN 11866, series B													Ø	C	D	D1	E	H1	H2	H3	H4	H5	X1	X	ISO 13.5	13.5x1.6	60	50	59	40	130	163	29.5	113	146	187	198	ISO 17.2	17.2x1.6	60	50	59	40	133	163	32.5	116	146	197	208
ISO	Outside diameter acc. to DIN EN ISO 1127, series II, DIN 11866, series B																																																																						
	Ø	C	D	D1	E	H1	H2	H3	H4	H5	X1	X																																																											
ISO 13.5	13.5x1.6	60	50	59	40	130	163	29.5	113	146	187	198																																																											
ISO 17.2	17.2x1.6	60	50	59	40	133	163	32.5	116	146	197	208																																																											
		<table border="1"> <thead> <tr> <th>Inch OD</th> <th colspan="12">Outside diameter acc. to ASME-BPE 1997, DIN 11866, series C</th> </tr> <tr> <th></th> <th>Ø</th> <th>C</th> <th>D</th> <th>D1</th> <th>E</th> <th>H1</th> <th>H2</th> <th>H3</th> <th>H4</th> <th>H5</th> <th>X1</th> <th>X</th> </tr> </thead> <tbody> <tr> <td>0.5" OD</td> <td>12.7x1.65</td> <td>60</td> <td>50</td> <td>59</td> <td>40</td> <td>130</td> <td>163</td> <td>29.5</td> <td>113</td> <td>146</td> <td>187</td> <td>198</td> </tr> <tr> <td>0.75" OD</td> <td>19.05x1.65</td> <td>60</td> <td>50</td> <td>59</td> <td>40</td> <td>133</td> <td>163</td> <td>32.5</td> <td>116</td> <td>146</td> <td>197</td> <td>208</td> </tr> </tbody> </table>																		Inch OD	Outside diameter acc. to ASME-BPE 1997, DIN 11866, series C													Ø	C	D	D1	E	H1	H2	H3	H4	H5	X1	X	0.5" OD	12.7x1.65	60	50	59	40	130	163	29.5	113	146	187	198	0.75" OD	19.05x1.65	60	50	59	40	133	163	32.5	116	146	197	208
Inch OD	Outside diameter acc. to ASME-BPE 1997, DIN 11866, series C																																																																						
	Ø	C	D	D1	E	H1	H2	H3	H4	H5	X1	X																																																											
0.5" OD	12.7x1.65	60	50	59	40	130	163	29.5	113	146	187	198																																																											
0.75" OD	19.05x1.65	60	50	59	40	133	163	32.5	116	146	197	208																																																											
		<p>X (included the clearance required for maintenance)</p>																																																																					

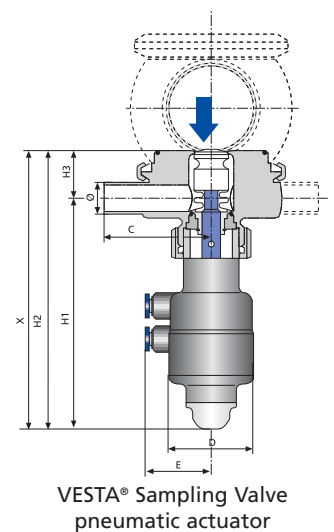
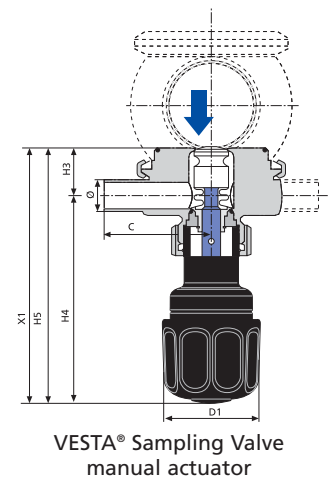

 Recommended flow direction

# VESTA® Sampling Valve, Type H\_A/I 2/2 Way Seat Valve

Example for an order code

Code	Code	H	L	A	I/N	P	NW	NW	M	Z	000	0	0	-	0	2	52	K	-
	Item	1	2	3	4	5	6	7	8	9	10	11	12	13	14	15	16	17	18

## 7. Nominal width, flange

See brochure VARINLINE® housings and connection flanges, Accessories Register 9

## 8. Type of actuator

P = synthetic material (PPS)

M = stainless steel (1.4301/316)

H = manual actuator (PPS)

## 9. Non-actuated position

Z = air-to-open/spring-to-close // and manual actuator

A = air-to-close/spring-to-open

J = air-to-open/air-to-close

Control air volume [dm<sup>3</sup>N]

Function	DN 10, 0.5" OD ISO 13.5	DN 15 0.75" OD	ISO 17.2
Z (NC)	0.011	0.013	0.014
A (NO)	0.026	0.026	0.028

## 10. Type/location of feedback element

TV<sub>1</sub> = position indicator / control module type T.VIS® V-1 (for nominal size up to DN 32, 1" OD, ISO 33.7)

TP<sub>1</sub> = position controller T.VIS® P-1 (for nominal size up to DN 32, 1" OD, ISO 33.7)

Ex = SEE / ATEX (only stainless steel actuator)

INA = proximity switch holder

ooo = visual indication (standard), (manual/pneumatic actuator)

## 11. Control module type / solenoid valve

N = without solenoid valve (TV<sub>1</sub>)

P = one solenoid valve (TV<sub>1</sub>, SEE)

I = two solenoid valves (TV<sub>1</sub>, TP<sub>1</sub>)

o = without solenoid valve (INA, ooo)

# VESTA® Sampling Valve, Type H\_A/I 2/2 Way Seat Valve

Example for an order code

Code	Code	H	L	A	I/N	P	NW	NW	M	Z	000	0	0	-	0	2	52	K	-
Code	Item	1	2	3	4	5	6	7	8	9	10	11	12	13	14	15	16	17	18

## 12. Number of feedback signals

o = without (ooo)  
 1 = one feedback signal (INA)  
 2 = two feedback signals (TV1, TP1, INA)

## 13. Type of sensor connection

A = AS Interface (TV1)  
 B = 24 V DC, 3 Draht, PNP (TV1, TV2o, TM1, INA)  
 N = 24 V DC, 3 Draht, NPN (TV1, INA)  
 D = DeviceNet (TV1)  
 E = EEX / ATEX (SEE, INA)  
 P = 24 V DC, programmable (TP1, TP2o)  
 X = proximity switch acc. to customer's specification

## 14. Electrical connection (cable gland) / air connection

o = without  
 D = 5-pin connector M 12 / Ø 6/4 mm (TV1, TP1, TM1, TV2o, TP2o)  
 K = 5-pin connector M 12 / Ø 6.35/4.35 mm, 0.25" OD - (TV1, TP1, TM1, TV2o, TP2o)  
 M = connection for air hose Ø 6/4 mm, proximity switch with terminal box and cable terminals (INA, ooo, manual actuator)  
 Z = connection for air hose 0.25" OD (6.35/4.35 mm), proximity switch with terminal box and cable terminals (INA, ooo)

## 15. Surface finish

1 = inside surfaces  $R_a \leq 0.8 \mu\text{m}$ , socket welds unpolished, body electrochemically cleaned  
 2 = inside surfaces  $R_a \leq 0.4 \mu\text{m}$ , socket welds polished, body electropolished

## 16. Valve tag

52 = adhesive plate

# VESTA® Sampling Valve, Type H\_A/I 2/2 Way Seat Valve

Example for an order code

Code	Code	H	L	A	I/N	P	NW	NW	M	Z	000	0	0	-	0	2	52	K	-
	Item	1	2	3	4	5	6	7	8	9	10	11	12	13	14	15	16	17	18
	<b>17. Certificates</b>																		
	<p>o = without                      Z = certificate acc. to EN10204-3.1                      W = factory test certificate EN10204-2.2                      F = ferrite content certificate                      O = surface test certificate                      K = certificate of FDA conformity                      U = certificate of USP class VI conformity                      X = acceptance acc. to customer's specification</p>																		
	<b>18. Accessories</b>																		
	<p>20 = stroke limiter open                      21 = seal adjuster close                      22 = 5 pin connector/junction box                      29 = quick release handle                      43 = VESTAMID®* - UV resistant material; for oil and fat containing control air</p> <p><small>*) VESTAMID® is registered as a trademark of the Degussa AG</small></p>																		

## The VARIVENT® / VARINLINE® housing

Even without the instrument, i.e. with the blanking plate, a perfect seal - no dome, no sump

Blanking plates to fit a variety of instruments

Rapid, accurate installation with hinged clamps

Suitable for a wide range of fittings

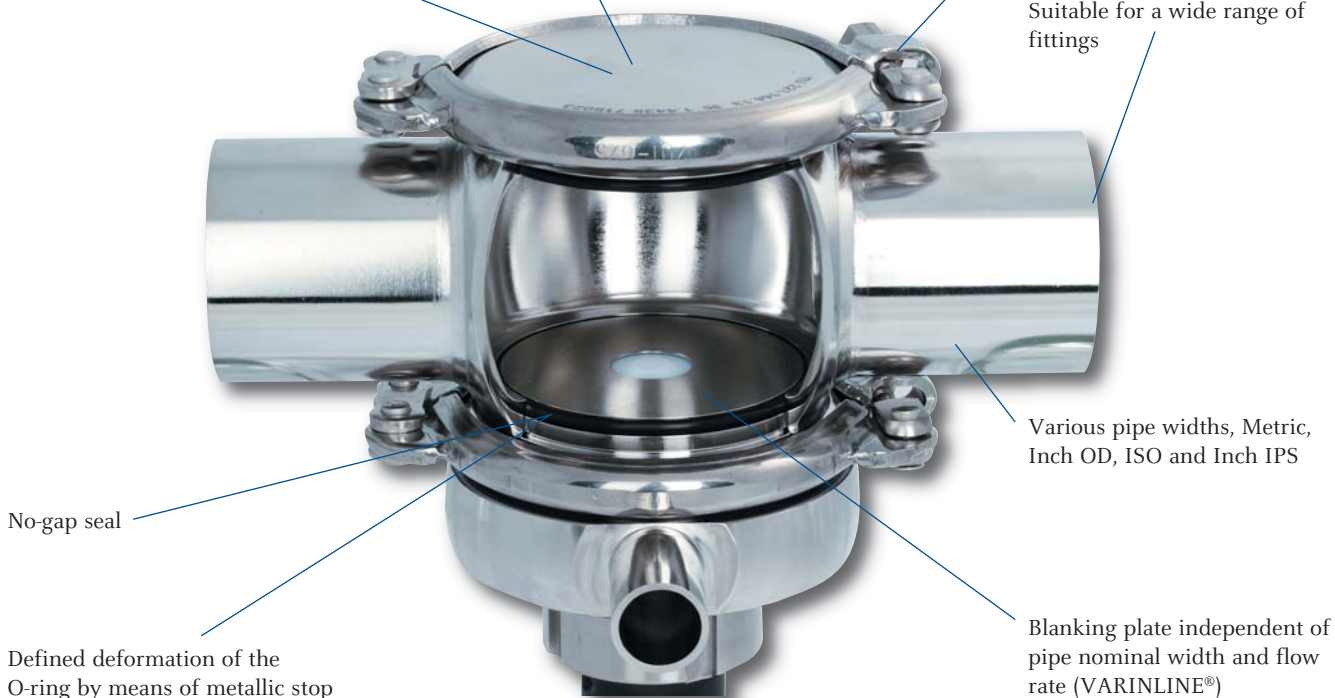

# VESTA® Sampling Valve, Type H\_A/I 2/2 Way Seat Valve

## Key figures

Ø	Stroke [mm]	Kv-Value [m³/h]			Weight acc. to actuator [kg]			
		I-II	I-III	III-I	Typ H_A/I			
					Synthetic	Stainless Steel	Manual	
<b>DIN</b> Outside socket diameter, acc. to DIN11866, series A / DIN11850, series II								
DN 10	13x1.5	2.1	2	2.3	2.1	0.86	1.32	0.86
DN 15	19x1.5	4	6.4	6.5	5.9	0.84	1.3	0.84
<b>Inch OD</b> Outside socket diameter, acc. to ASME-BPE, DIN11866, series C								
0.5" OD	12.7x1.65	2.1	2.1	2.2	2.2	0.86	1.32	0.86
0.75" OD	19.05x1.65	4	6.6	6.9	6	0.84	1.3	0.84
<b>ISO</b> Outside socket diameter, acc. to DIN EN ISO1127, DIN11866, series B								
ISO 13.5	13.5x1.6	2.1	2.4	2.8	2.5	0.86	1.32	0.86
ISO 17.2	17.2x1.6	2.9	4.1	5.2	4.5	0.84	1.3	0.84

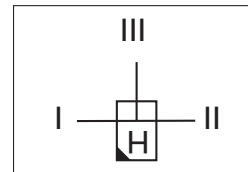

Kv- flow direction

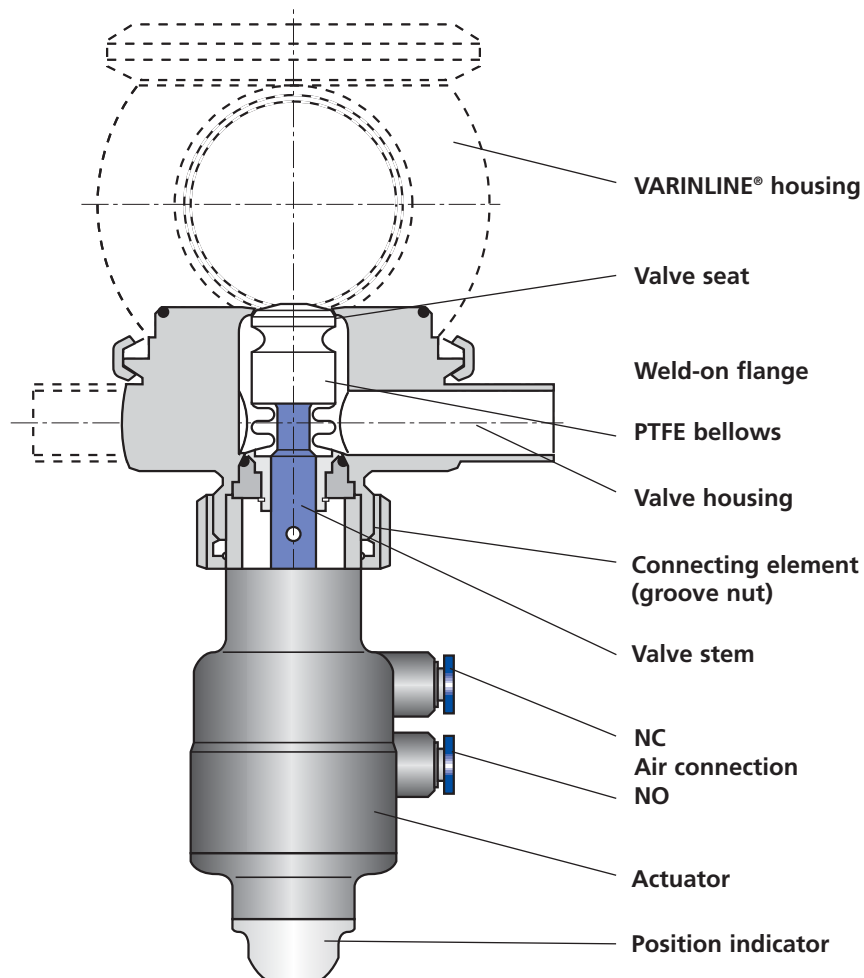



GEA Mechanical Equipment

**GEA Tuchenhagen GmbH**

Am Industriepark 2-10, 21514 Büchen, Germany

Phone +49-4155 49-0, Fax +49-4155 49-2423

sales.geatuchenhagen@geagroup.com, [www.tuchenhagen.com](http://www.tuchenhagen.com)